

ArcSafe™, ArcSafe™-SW and MultiClutch™

Robotic Collision Protection 



The ArcSafe™, MultiClutch™ and the NEW ArcSafe™-SW provide maximum collision protection in robotic applications.

The **AMERICAN WELDQUIP** ArcSafe and MultiClutch utilize an integrated switch designed to prevent damage to the robotic end of arm equipment and/or tooling. In the event of a “crash” situation with the end of arm equipment the switch activates the E-Stop circuit, thus stopping the robot movement.

The NEW ArcSafe-SW is specifically designed for use in robotic application where the crash protection is integrated into the robotic software package. Most integrated robotic collision detection software systems take time to come to a complete stop - especially with high speed movements. This is where the ArcSafe-SW offers additional protection over solid mount type devices.

The built-in spring deflection feature allows the ArcSafe-SW to deflect the end of arm equipment in the event of a crash. This additional safe guard provides the extra protection required to reduce or eliminate bent goosenecks, cracked insulating disks, and damaged tooling.

The ArcSafe, ArcSafe-SW and MultiClutch models are an inexpensive investment to protect equipment, tooling, reduce or eliminate expensive downtime and maintenance issues.

ArcSafe Features:

- **Highly Repeatable** – Resets to $\pm .001''$ ($\pm .025\text{mm}$)
- **Rugged Design** – Hardened tool steel in contact and wear points.
- **Common Work Envelope** – interchangeability when changing out competitive brands.
- **Robust E-Stop Control Cable/Connector** – Heavy control cable and robust connector mean less downtime because of cable issues.
- **Protection in Mx, My, Mz and Fz Directions**
- **Arm Mounting Post** – Hardened tool steel and flat surface for fast and precise wedge pin mounting of torch arms.
- **Quick Field Replaceable Switch Assembly**
- **Easy Sensitivity Adjustment**
- **Air Assist - Standard**
- **Quick Installation** – Only four screws with common Allen Key Wrench.
- **Protective Seal Boot** – Keeps weld spatter out of mounting screws and other critical areas for reduced downtime and maintenance.

MultiClutch Features:

- **All the ArcSafe Features** – The MultiClutch offers all the features and benefits of the ArcSafe above.
- **Tooling Mount Flange** – The MultiClutch comes configured with a tooling mounting flange. This flange allows the user to mount different types of equipment to the end of the robot arm. This might include equipment for material handling, gluing, painting, inspection etc..

ArcSafe-SW Features:

- **Highly Repeatable** – Resets to $\pm .001''$ ($\pm .025\text{mm}$)
- **Provides added Protection in Mx, My, Mz and Fz Directions over solid mount designs.**
- **Rugged Design** – Hardened tool steel in contact and wear points.
- **Common Work Envelope** – interchangeability when changing out competitive brands.
- **Arm Mounting Post** – Hardened tool steel and flat surface for fast and precise wedge pin mounting of torch arms.
- **Air Assist - Standard**
- **Quick Installation** – Only four screws with common Allen Key Wrench.
- **Protective Seal Boot** – Keeps weld spatter out of mounting screws and other critical areas for reduced downtime and maintenance.

ArcSafe/ArcSafe-SW

Dimensional Specifications

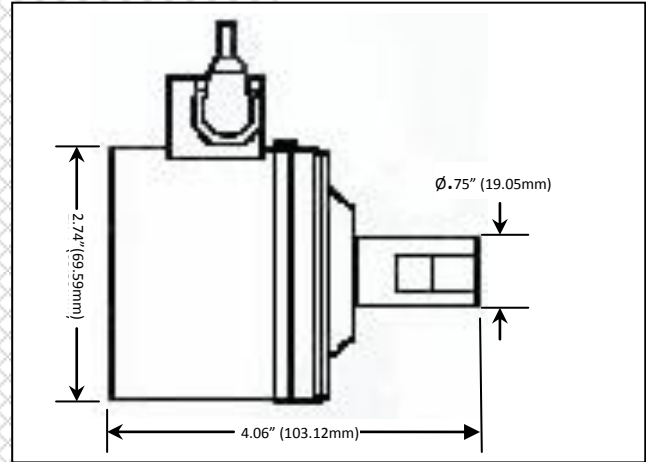

Technical Specifications – ArcSafe, ArcSafe-SW, MultiClutch

- Weight – 1lb. 9 oz. (.709 KG)
- Repeatability - ± .001" (± .025mm)
- Range Of Travel - 20° Pivot, 360° Rotation
- Spring Force - .50" (12.7mm) Compression
- Mx, My = 93 in-lbs
- Mz = 168 in.lbs.
- Fz = 172 lbs.

HOW TO ORDER

PART NUMBER	DESCRIPTION
AH1881	ArcSafe Robotic Collision Sensor
MH3523	MultiClutch Robotic Collision Sensor
ASW2000	ArcSafe-SW for use with robotic collision detection software
AS-B-A	Solid Mount

INSULATION DISKS

PART NUMBER	DESCRIPTION
AS-100	FANUC - 50IL
AS-300M	FANUC - S-5, JR55,SR510, S5, KUKA - KR-6, KR-15, Panasonic - AW-005A, AW-500C, AW-500CL, AW-006A, AW010A, AW-8010,VR-005C, VR-006ALII, VR-006A, VR-006AL, VR-008A
AS-400M	ABB - IRB6, IRB140, IRB1400,IRB1500, IRB2000, IRB2400, FANUC - ARCMATE 100, 100i, 120i, 100iB, S-6, MOTOMAN - K6, SK6, SK16, SK20, UP6, UP20, MILLER - MRV-2, MRV-10 OTC – MRV-6, EX-V6, EX-V6L, EX-V16, DR4000, DR4200, DR4400
AS-700	NACHI – SC06F

ADAPTOR PLATES – USE WITH MULTICLUTCH

PART NUMBER	DESCRIPTION
501608M	Fanuc - Arcmate Jr. and Sr. (4-40mm)
501884	50mm Export
502909M	Fanuc - Arcmate 100, 110
503191M	Motoman - K6, K10
503204M	ARC 100 Insulated Delron

